

Altivar 71

Integrated Modbus

User's manual

11/2009

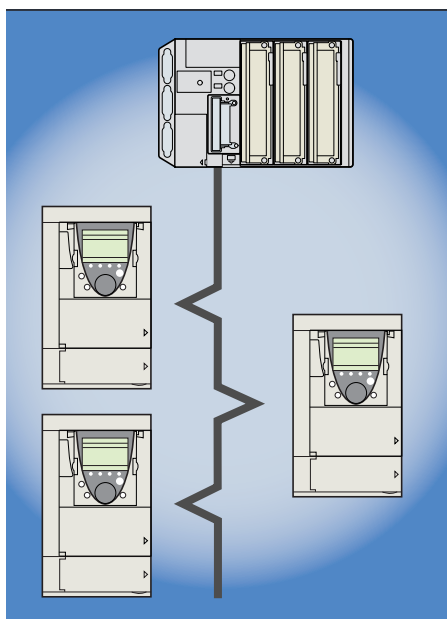

Contents

Before you begin	4
Documentation structure	5
Introduction	6
Presentation	6
Notation	6
Bus connection	7
Connecting to the Altivar 71	7
RJ45 connector pinouts	7
Wiring recommendations	8
RS485 standard	8
Modbus standard schematic	9
Connection via RJ45 wiring system	10
Connection via junction boxes	12
Connection onto screw terminals	14
Configuration	15
Configuring communication parameters	15
Control-signal configuration	16
Configuring the communication scanner	19
Configuring monitored parameters	20
Configuring communication fault management	21
Diagnostics	22
LEDs	22
Communication diagnostics	23
Control-signal diagnostics	25
Communication faults	27
Modbus protocol	28
RTU mode	28
Principle	28
Altivar 71 Integrated Modbus	29
Addresses	29
Modbus functions	30
Read N output words: Function 3	30
Write one output word: Function 6	31
Diagnostics: Function 8	32
Write N output words: Function 16 (16#10)	33
Identification: Function 43 (16#2B)	34
Read/write N words: Function 23 (16#17)	36
Communication scanner	37
Exception responses	39
Read non-existent or protected parameters	39
Appendix: Non-standard schematics	41
UNI-TELWAY schematic	41
Jbus schematic	42
Use of UNI-TELWAY slaves in a standard schematic	43
Recommendations for setting up a Modbus network using non-standard devices	44

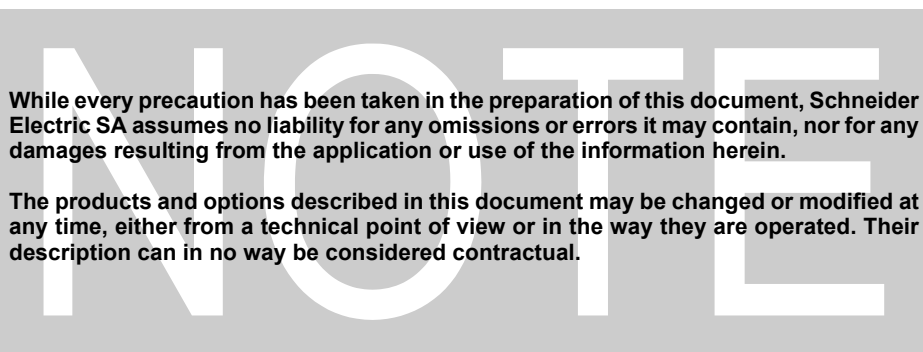

Before you begin

Read and understand these instructions before performing any procedure with this drive.

DANGER

HAZARDOUS VOLTAGE

- Read and understand this manual before installing or operating the Altivar 71 drive. Installation, adjustment, repair, and maintenance must be performed by qualified personnel.
- The user is responsible for compliance with all international and national electrical standards in force concerning protective grounding of all equipment.
- Many parts in this variable speed drive, including printed wiring boards, operate at line voltage. DO NOT TOUCH. Use only electrically insulated tools.
- DO NOT touch unshielded components or terminal strip screw connections with voltage present.
- DO NOT short across terminals PA and PC or across the DC bus capacitors.
- Install and close all covers before applying power or starting and stopping the drive.
- Before servicing the variable speed drive:
 - Disconnect all power
 - Place a "DO NOT TURN ON" label on the variable speed drive disconnect
 - Lock the disconnect in the open position
- Disconnect all power including external control power that may be present before servicing the drive. WAIT 15 MINUTES for the DC bus capacitors to discharge. Then follow the DC bus voltage measurement procedure given in the Installation Manual to verify that the DC voltage is less than 45 Vdc. The drive LEDs are not accurate indicators of the absence of DC bus voltage.

Electric shock will result in death or serious injury

CAUTION

DAMAGED EQUIPMENT

Do not operate or install any drive that appears damaged.
Failure to follow this instruction can result in equipment damage.

Documentation structure

Installation manual

This manual describes:

- How to assemble the drive
- How to connect the drive

Programming manual

This manual describes:

- The functions
- The parameters
- How to use the drive display terminal (integrated display terminal and graphic display terminal)

Communication parameters manual

This manual describes:

- The drive parameters with specific information (addresses, formats, etc.) for use via a bus or communication network
- The operating modes specific to communication (status chart)
- The interaction between communication and local control

Modbus, CANopen, Ethernet, Profibus, INTERBUS, Uni-Telway, FIPIO, DeviceNet, Modbus Plus manuals ...

These manuals describe:

- Connection to the bus or network
- Configuration of the communication-specific parameters via the integrated display terminal or the graphic display terminal
- Diagnostics
- Software setup
- The communication services specific to the protocol

Altivar 58/58F migration manual

This manual describes the differences between the Altivar 71 and the Altivar 58/58F.

It explains how to replace an Altivar 58 or 58F, including how to replace drives communicating on a bus or network.

Introduction

Presentation

Two integrated communication ports mean that the Modbus protocol can be accessed directly:

- One RJ45 Modbus HMI connector port, located on the drive front panel, which is used to connect:
 - The graphic display terminal
 - A Magelis industrial HMI terminal
 - The PowerSuite software workshop
- One RJ45 Modbus network port, located on the drive control terminals, which is dedicated to control and signaling by a PLC or other type of controller. It also supports the connection of a terminal or the PowerSuite software workshop when the terminal port is not available.

The two Modbus ports on the Altivar 71 can be used for the following functions:

- Configuration
- Adjustment
- Control
- Monitoring

The Altivar 71 supports:

- The 2-wire RS485 physical layer
- The RTU transmission mode

This manual describes how to set up the Altivar 71 drive on Modbus and also describes the Modbus services that are available on this drive.

Notation

Drive terminal displays

The graphic display terminal menus are shown in square brackets.

Example: **[1.9 COMMUNICATION]**.

The integrated 7-segment display terminal menus are shown in round brackets.

Example: **(C D P -)**.

Parameter names are displayed on the graphic display terminal in square brackets.

Example: **[Fallback speed]**

Parameter codes are displayed on the integrated 7-segment display terminal in round brackets.

Example: **(L F F)**.

Formats

In this manual, hexadecimal values are written as follows: 16#.

Bus connection

Connecting to the Altivar 71

Connection accessories should be ordered separately (please consult our catalogs).

Connect the RJ45 cable connector to either of the RJ45 connectors on the Altivar 71:

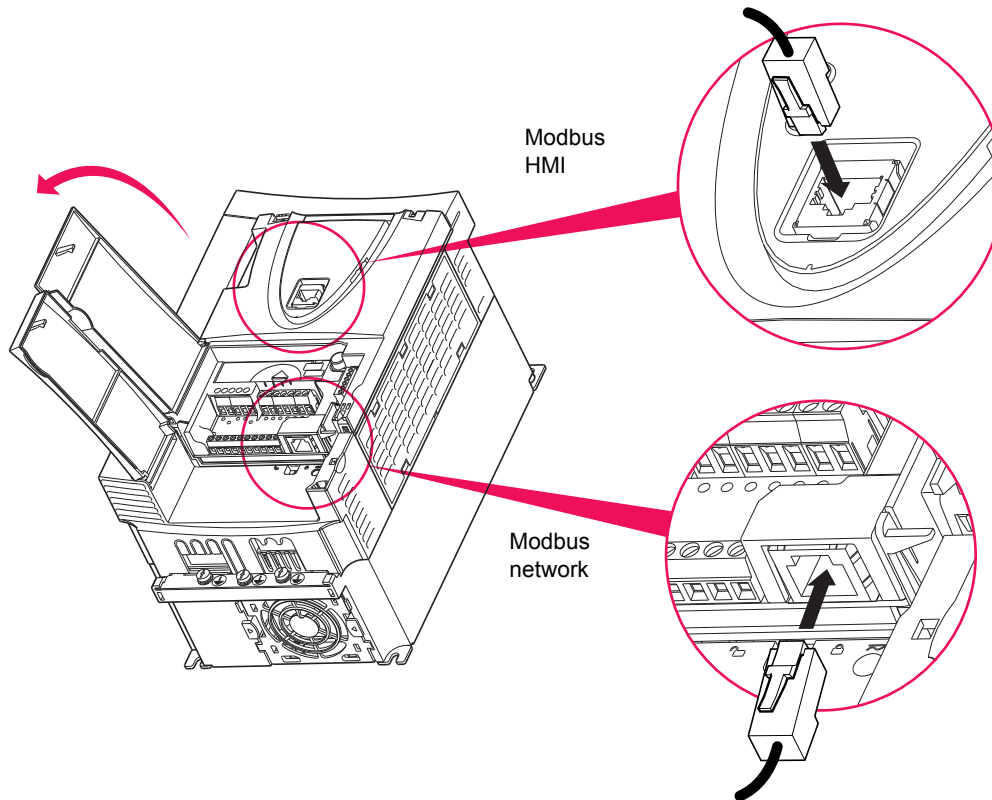

RJ45 connector pinouts

View from underneath

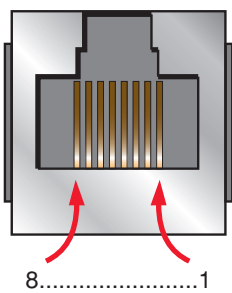

Modbus network

Pin	Signal
1	CAN_H (1)
2	CAN_L (1)
3	CAN_GND (1)
4	D1
5	D0
6	Not connected
7	VP (2)
8	Common

Modbus HMI

Pin	Signal
1	Not connected
2	Not connected
3	Not connected
4	D1
5	D0
6	Not connected
7	VP (2)
8	Common

(1)CANopen signal.

(2)Power supply (\approx 10 V 20 mA) for an RS232/RS485 converter (to PowerSuite) or for the graphic display terminal.

Note: Avoid using pins marked "Not connected".

Bus connection

Wiring recommendations

- Use the Schneider-Electric cable with 2 pairs of shielded twisted conductors (catalog number: TSXCSA100, TSXCSA200 or TSXCSA500).
- Keep the Modbus cable away from the power cables (30 cm minimum).
- If it is necessary for the Modbus cable and the power cables to cross each other, be sure they cross at right angles.
- Whenever possible, connect the cable shielding to the protective ground, e.g., to the ground of each device if this ground is connected to the protective ground.
- Install a line terminator at both ends of the line.
- Ensure the correct polarization of the line.
- Connect the common polarity ("Common" signal) to the protective ground at one or more points on the bus.

For more information, please refer to the TSX DG KBL E guide: "Electromagnetic compatibility of industrial networks and fieldbuses".

RS485 standard

The RS485 standard allows variants of different characteristics:

- Polarization
- Line terminator
- Distribution of a reference potential
- Number of slaves
- Length of bus

The new Modbus specification published on www.modbus.org in 2002 contains precise details of all these characteristics. They are also summarized in the next paragraph (standard schematic). The new Schneider-Electric devices conform to this specification.

Some devices comply with earlier specifications. The two most widespread are described in the appendices:

- "Uni-Telway schematic" page [41](#)
- "Jbus schematic" page [42](#)

Requirements enabling different types of protocol to coexist are given in the appendix:

- "Mixed schematic" page [43](#)

Bus connection

Modbus standard schematic

The standard schematic corresponds to the Modbus specification published in 2002 on www.modbus.org (Modbus_over_serial_line_V1.pdf, Nov 2002) and in particular to the schematic of the 2-wire multidrop serial bus.

The ATV71 drive conforms to this specification.

Schematic diagram:

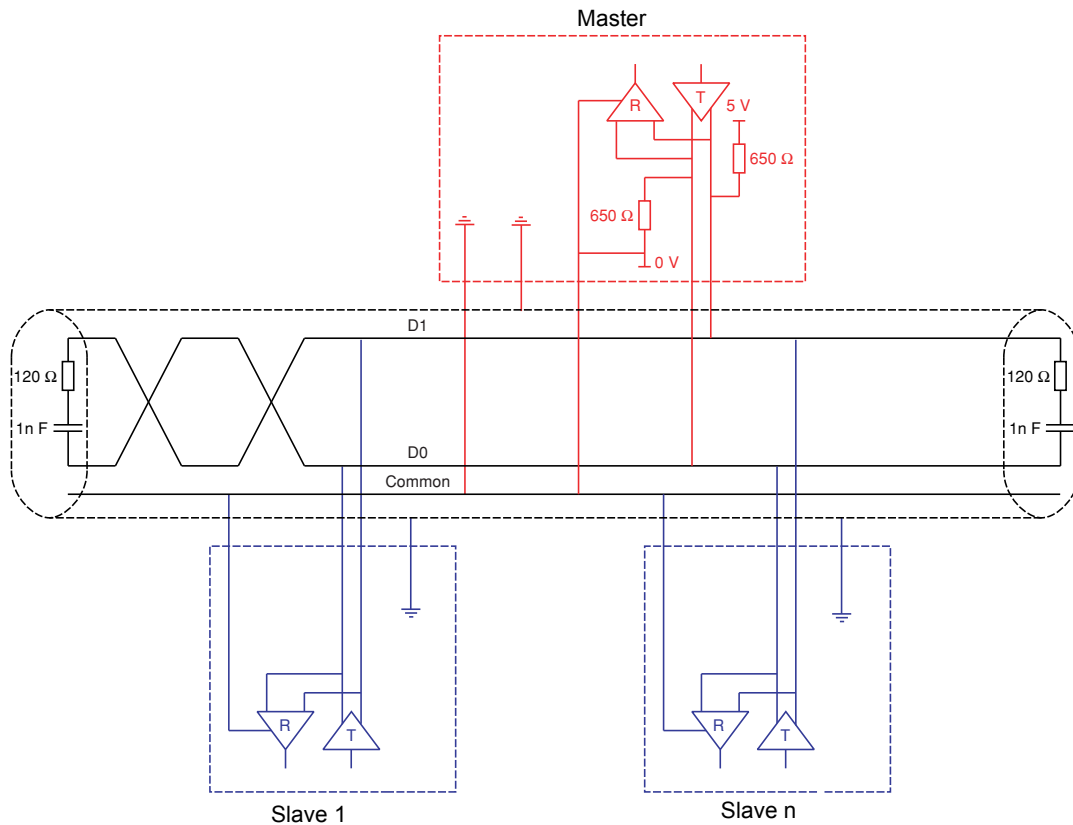

Type of trunk cable	Shielded cable with 1 twisted pair and at least a 3 rd conductor
Maximum length of bus	1000 m at 19200 bps with the Schneider-Electric TSX CSA● cable
Maximum number of stations (without repeater)	32 stations, i.e., 31 slaves
Maximum length of tap links	<ul style="list-style-type: none"> • 20 m for one tap link • 40 m divided by the number of tap links on a multiple junction box
Bus polarization	<ul style="list-style-type: none"> • One 450 to 650 Ω pull-down resistor at 5 V (650 Ω or thereabouts recommended) • One 450 to 650 Ω pull-down resistor at Common (650 Ω or thereabouts recommended) This polarization is recommended for the master.
Line terminator	One 120 Ω 0.25 W resistor in series with a 1nF 10 V capacitor
Common polarity	Yes (Common), connected to the protective ground at one or more points on the bus

Bus connection

Connection via RJ45 wiring system

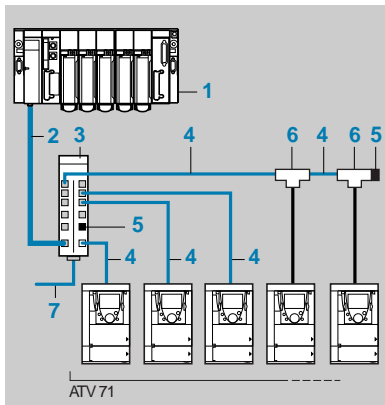

1. Master (PLC, PC or communication module)
2. Modbus cable depending on the type of master (see table)
3. Modbus splitter block **LU9 GC3**
4. Modbus drop cables **VW3 A8 306 R●●**
5. Line terminators **VW3 A8 306 RC**
6. Modbus T-junction boxes **VW3 A8 306 TF●●** (with cable)
7. Modbus cable (to another splitter block) **TSX CSA●00**

Connection accessories

Description		Code	Catalog number	
Modbus splitter block	10 RJ45 connectors and 1 screw terminal block	3	LU9 GC3	
Modbus T-junction boxes	With integrated cable (0.3 m)	6	VW3 A8 306 TF03	
	With integrated cable (1 m)	6	VW3 A8 306 TF10	
Line terminators	For RJ45 connector	R = 120 Ω, C = 1 nF	5	VW3 A8 306 RC
		R = 150 Ω (specific to "Jbus schematic" page 42)	5	VW3 A8 306 R

Connecting cables

Description	Length (m)	Connectors	Code	Catalog number
Cables for Modbus bus	3	1 RJ45 connector and 1 stripped end		VW3 A8 306 D30
	0.3	2 RJ45 connectors	4	VW3 A8 306 R03
	1	2 RJ45 connectors	4	VW3 A8 306 R10
	3	2 RJ45 connectors	4	VW3 A8 306 R30
RS 485 double shielded twisted pair cables	100	Supplied without connector	7	TSX CSA 100
	200	Supplied without connector	7	TSX CSA 200
	500	Supplied without connector	7	TSX CSA 500

Bus connection

Type of master	Master interface	Modbus connection accessories for RJ45 wiring system	
		Description	Catalog number
Twido PLC	Adaptor or mini-DIN RS485 interface module	3 m cable equipped with a mini-DIN connector and an RJ45 connector	TWD XCA RJ030
	Adaptor or screw terminal RS485 interface module	3 m cable equipped with an RJ45 connector and stripped at the other end	VW3 A8 306 D30
TSX Micro PLC	Mini-DIN RS485 connector port	3 m cable equipped with a mini-DIN connector and an RJ45 connector	TWD XCA RJ030
	PCMCIA card (TSX SCP114)	Stripped cable	TSX SCP CM 4030
TSX Premium PLC	TSX SCY 11601 or TSX SCY 21601 module (SUB-D 25 socket)	Cable equipped with a SUB-D 25 connector and stripped at the other end (for connection to the screw terminals of the LU9GC3 splitter block)	TSX SCY CM 6030
	PCMCIA card (TSX SCP114)	Stripped cable	TSX SCP CM 4030
Ethernet bridge (174 CEV 300 10)	Screw terminal RS485	3 m cable equipped with an RJ45 connector and stripped at the other end	VW3 A8 306 D30
Profibus DP gateway (LA9P307)	RJ45 RS485	1 m cable equipped with 2 RJ45 connectors	VW3 P07 306 R10
Fipio (LUFP1) or Profibus DP (LUFP7) or DeviceNet (LUFP9) gateway	RJ45 RS485	0.3 m cable equipped with 2 RJ45 connectors or 1 m cable equipped with 2 RJ45 connectors or 3 m cable equipped with 2 RJ45 connectors	VW3 A8 306 R03 or VW3 A8 306 R10 or VW3 A8 306 R30
Serial port PC	Male SUB-D 9 RS232 serial port PC	RS232/RS485 converter and 3 m cable equipped with an RJ45 connector and stripped at the other end (for connection to the screw terminals of the LU9GC3 splitter block)	TSX SCA 72 and VW3 A8 306 D30

Bus connection

Connection via junction boxes

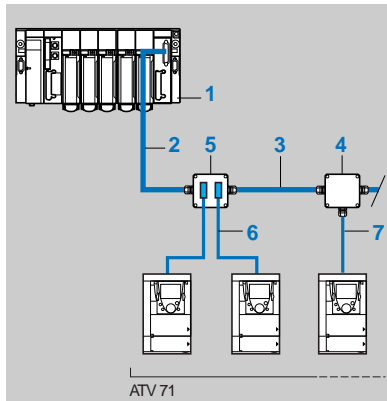

1. Master (PLC, PC or communication module)
2. Modbus cable depending on the type of master
3. Modbus cable **TSX CSA●00**
4. Junction box **TSX SCA 50**
5. Subscriber sockets **TSX SCA 62**
6. Modbus drop cables **VW3 A8 306**
7. Modbus drop cable **VW3 A8 306 D30**

Connection accessories

Description	Code	Catalog number
Tap junction 3 screw terminals and an RC line terminator, to be connected using cable VW3 A8 306 D30	4	TSX SCA 50
Subscriber socket 2 female 15-way SUB-D connectors, 2 screw terminals, and an RC line terminator, to be connected using cable VW3 A8 306 or VW3 A8 306 D30	5	TSX SCA 62

Connecting cables

Description	Length (m)	Connectors	Code	Catalog number
Cables for Modbus bus	3	1 RJ45 connector and one stripped end	7	VW3 A8 306 D30
	3	1 RJ45 connector and 1 male 15-way SUB-D connector for TSX SCA 62	6	VW3 A8 306
RS 485 double shielded twisted pair cables	100	Supplied without connector	3	TSX CSA 100
	200	Supplied without connector	3	TSX CSA 200
	500	Supplied without connector	3	TSX CSA 500

Bus connection

Type of master	Master interface	Modbus connection accessories for junction boxes using screw terminals	
		Description	Catalog number
Twido PLC	Adaptor or screw terminal RS485 interface module	Modbus cable	TSX CSA100 or TSX CSA200 or TSX CSA500
TSX Micro PLC	Mini-DIN RS485 connector port	Tap junction	TSX P ACC 01
	PCMCIA card (TSX SCP114)	Cable equipped with a special connector and stripped at the other end	TSX SCP CU 4030
TSX Premium PLC	TSX SCY 11601 or TSX SCY 21601 module (SUB-D 25 socket)	Cable equipped with a SUB-D 25 connector and stripped at the other end	TSX SCY CM 6030
	PCMCIA card (TSX SCP114)	Cable equipped with a special connector and stripped at the other end	TSX SCP CU 4030
Ethernet bridge (174 CEV 300 10)	Screw terminal RS485	Modbus cable	TSX CSA100 or TSX CSA200 or TSX CSA500
Profibus DP gateway (LA9P307)	RJ45 RS485	3 m cable equipped with an RJ45 connector and stripped at the other end	VW3 A8 306 D30
Fipio (LUFP1) or Profibus DP (LUFP7) or DeviceNet (LUFP9) gateway	RJ45 RS485	3 m cable equipped with an RJ45 connector and stripped at the other end	VW3 A8 306 D30
Serial port PC	Male SUB-D 9 RS232 serial port PC	RS232/RS485 converter and Modbus cable	TSX SCA 72 and TSX CSA100 or TSX CSA200 or TSX CSA500

Type of master	Master interface	Modbus connection accessories for junction boxes using SUB-D 15	
		Description	Catalog number
Twido PLC	Adaptor or screw terminal RS485 interface module	-	-
TSX Micro PLC	Mini-DIN RS485 connector port	-	-
	PCMCIA card (TSX SCP114)	Cable equipped with a special connector and a SUB-D 25 connector	TSX SCY CU 4530
TSX Premium PLC	TSX SCY 11601 or TSX SCY 21601 module (SUB-D 25 socket)	Cable equipped with a SUB-D 25 connector and stripped at the other end	TSX SCP CU 4530
	PCMCIA card (TSX SCP114)	Cable equipped with a special connector and stripped at the other end	TSX SCY CU 4530
Ethernet bridge (174 CEV 300 10)	Screw terminal RS485	-	-
Profibus DP gateway (LA9P307)	RJ45 RS485	-	-
Fipio gateway (LUFP1) or Profibus DP gateway (LUFP7)	RJ45 RS485	3 m cable equipped with an RJ45 connector and a SUB-D 25 connector	VW3 A8 306
Serial port PC	Male SUB-D 9 RS232 serial port PC	-	-

Bus connection

Connection onto screw terminals

Connection accessories

Description			Catalog number
Line terminators	For screw terminals	R = 120 Ω , C = 1 nF	VW3 A8 306 DRC
		R = 150 Ω (specific to "Jbus schematic" page 42)	VW3 A8 306 DR

Connecting cables

Description	Length (m)	Connectors	Catalog number
Cables for Modbus bus	3	1 RJ45 connector and one stripped end	VW3 A8 306 D30
RS 485 double shielded twisted pair cables	100	Supplied without connector	TSX CSA 100
	200	Supplied without connector	TSX CSA 200
	500	Supplied without connector	TSX CSA 500

Configuration

Configuring communication parameters

Modbus network

The configuration of the Modbus network parameters can be accessed via the **[1.9 - COMMUNICATION] (C O N -)** menu (**[MODBUS NETWORK] (n d 1 -)** submenu).

Modbus parameter	Description/Possible values	display Terminal	value Default
[Modbus Address] (A d d)	1 to 247 Drive Modbus server disabled	[1] (1) to [247] (2 4 7) [Off] (O F F)	[Off] (O F F)
[Modbus add CI card] (A n d A)	1 to 247 "Controller inside" card Modbus server disabled	[1] (1) to [247] (2 4 7) [Off] (O F F)	[Off] (O F F)
[MdbS add com card] (A n d C)	1 to 247 (Ethernet) communication card Modbus server disabled	[1] (1) to [247] (2 4 7) [Off] (O F F)	[Off] (O F F)
[Modbus baud rate] (t b r)	4800 bps 9600 bps 19200 bps (1) 38400 bps	[4.8 Kbps] (4 8) [9.6 Kbps] (9 6) [19.2 Kbps] (1 9 2) [38.4 Kbps] (3 8 4)	[19.2 Kbps] (1 9 2)
[Modbus format] (t F D)	8 data bits, odd parity, 1 stop bit 8 data bits, even parity, 1 stop bit (1) 8 data bits, no parity, 1 stop bit 8 data bits, no parity, 2 stop bits	[8-O-1] (8 0 1) [8 E 1] (8 E 1) [8-N-1] (8 n 1) [8-N-2] (8 n 2)	[8 E 1] (8 E 1)

The addresses are applicable to both Modbus network and Modbus HMI. These 3 addresses can be freely chosen and must all be different. To access the drive parameters, which are described in the parameters manual, just use the address **[Modbus Address] (A d d)**. The addresses **[Modbus add CI card] (A n d A)** and **[MdbS add com card] (A n d C)** are used solely for accessing the "Controller Inside" (catalog number: VW3 A3 510) and Ethernet (catalog number: VW3 A3 310) option card parameters.

Modbus HMI

The configuration of the Modbus HMI parameters can be accessed via the **[1.9 - COMMUNICATION] (C O N -)** menu (**[MODBUS HMI] (n d 2 -)** submenu).

Note: The drive address on Modbus HMI is identical to that on Modbus network. If Modbus network is disabled (value 0 or display "OFF"), the Modbus HMI connection remains active for the graphic display terminal and for PowerSuite.

Parameter	Possible values	Terminal display	Default value
[HMI baud rate] (t b r 2)	9600 bps 19200 bps (1)	[9.6 Kbps] (9 6) [19.2 Kbps] (1 9 2)	[19.2 Kbps] (1 9 2)
[HMI format] (t F D 2)	8 data bits, even parity, 1 stop bit (1)	[8 E 1] (8 E 1)	[8 E 1] (8 E 1)

(1) The graphic display terminal will only work with these values.
Any other value will make communication with the graphic display terminal impossible.

Configuration

Control-signal configuration

Numerous control-signal configurations are possible. For more information, refer to the programming manual and the parameters manual. The following configurations are just some of the possibilities available.

Control via Modbus in I/O profile

The command and target come from Modbus.
The command is in I/O profile.

Configure the following parameters:

Parameter	Value	Comment
Profile	I/O profile	The run command is simply obtained by bit 0 of the command word.
Target 1 configuration	Modbus	The target comes from Modbus.
Command 1 configuration	Modbus	The command comes from Modbus.

Configuration via the graphic display terminal or the integrated display terminal:

Menu	Parameter	Value
[1.6 - COMMAND] (C E L -)	[Profile] (C H C F)	[I/O profile] (I O)
	[Ref.1 chan] (F r I)	[Modbus] (M o d b)
	[Cmd channel 1] (C d I)	[Modbus] (M o d b)

Control via Modbus or the terminals in I/O profile

Both the command and target come from Modbus or the terminals. Input LI5 at the terminals is used to switch between Modbus and the terminals.

The command is in I/O profile.

Configure the following parameters:

Parameter	Value	Comment
Profile	I/O profile	The run command is simply obtained by bit 0 of the command word.
Target 1 configuration	Modbus	Target 1 comes from Modbus.
Target 1B configuration	Analog input 1 on the terminals	Target 1B comes from input AI1 on the terminals.
Target switching	Input LI5	Input LI5 switches the target (1 ↔ 1B).
Command 1 configuration	Modbus	Command 1 comes from Modbus.
Command 2 configuration	Terminals	Command 2 comes from the terminals.
Command switching	Input LI5	Input LI5 switches the command.

Target 1B is connected to the functions (summing, PID, etc.), which remain active, even after switching.

Configuration

Configure the following parameters:

Menu	Parameter	Value
[1.6 - COMMAND] (C E L -)	[Profile] (C H C F)	[I/O profile] (I O)
	[Ref.1 chan] (F r 1)	[Modbus] (M d b)
	[Cmd channel 1] (C d 1)	[Modbus] (M d b)
	[Cmd channel 2] (C d 2)	[Terminals] (T E r)
	[Command switching] (C C S)	[LI5] (L I 5)
[1.7 - APPLICATION FUNCT.] (F U n) [REFERENCE SWITCH.]	[Ref.1B chan] (F r 1 B)	[AI1 ref.] (A I 1)
	[Ref 1B switching] (r C b)	[LI5] (L I 5)

Control via Modbus in Drivecom profile

The command and target come from Modbus.
The command is in Drivecom profile.

Configure the following parameters:

Parameter	Value	Comment
Profile	Combined Drivecom profile	The run commands are in Drivecom profile, the command and the target come from the same channel.
Target 1 configuration	Modbus	The command comes from Modbus.

Configuration via the graphic display terminal or the integrated display terminal

Menu	Parameter	Value
[1.6 - COMMAND] (C E L -)	[Profile] (C H C F)	[Combined] (S I n) (factory setting)
	[Ref.1 chan] (F r 1)	[Modbus] (M d b)

Control via Modbus or the terminals in Drivecom profile

Both the command and target come from Modbus or the terminals. Input LI5 at the terminals is used to switch between Modbus and the terminals. The command is in Drivecom profile.

Configure the following parameters:

Parameter	Value	Comment
Profile	Combined Drivecom profile	The run commands are in Drivecom profile, the command and the target come from the same channel.
Target 1 configuration	Modbus	Target 1 comes from Modbus.
Target 2 configuration	Analog input 1 on the terminals	Target 2 comes from input AI1 on the terminals.
Target switching	Input LI5	Input LI5 switches the target (1 ↔ 2) and the command.

Note: Target 2 is directly connected to the drive's reference limit. In the event of switching, the functions that have an effect on the target (summing, PID, etc.) are disabled.

Configuration via the graphic display terminal or the integrated display terminal:

Menu	Parameter	Value
[1.6 - COMMAND] (C E L -)	[Profile] (C H C F)	[Combined] (S I n)
	[Ref.1 chan] (F r 1)	[Modbus] (M d b)
	[Ref.2 chan] (F r 2)	[AI1 ref.] (A I 1)
	[Ref. 2 switching] (r F C)	[LI5] (L I 5)

Configuration

Control in Drivecom profile via Modbus and target switching at the terminals

The command comes from Modbus.

The command comes either from Modbus or from the terminals. Input LI5 at the terminals is used to switch the target between Modbus and the terminals.

The command is in Drivecom profile.

Configure the following parameters:

Parameter	Value	Comment
Profile	Separate Drivecom profile	The run commands are in Drivecom profile, the command and the target can come from different channels.
Target 1 configuration	Modbus	Target 1 comes from Modbus.
Target 1B configuration	Analog input 1 on the terminals	Target 1B comes from input AI1 on the terminals.
Target switching	Input LI5	Input LI5 switches the target (1 ↔ 1B).
Command 1 configuration	Modbus	Command 1 comes from Modbus.
Command switching	Channel 1	Channel 1 is the command channel.

Target 1B is connected to the functions (summing, PID, etc.), which remain active, even after switching.

Configuration via the graphic display terminal or the integrated display terminal:

Menu	Parameter	Value
[1.6 - COMMAND] (CEL -)	[Profile] (CHEF)	[Separate] (SEP)
	[Ref.1 chan] (Fr 1)	[Modbus] (Modb)
	[Cmd channel 1] (Cd 1)	[Modbus] (Modb)
	[Command switching] (CC5)	[ch1 active] (cd 1)
[1.7 - APPLICATION FUNCT.] (FUN) [REFERENCE SWITCH.]	[Ref.1B channel] (Fr 1b)	[AI1 ref.] (AI1)
	[Ref 1B switching] (rCb)	[LI5] (LI5)

Configuration

Configuring the communication scanner

Advantages of the communication scanner

The communication scanner enables all the application-relevant parameters to be grouped in 2 consecutive word tables so that single read and write operations may be performed. Even combined single operations are possible using the 23 = 16#17 Read/Write Multiple Registers function.

The 8 periodic output variables are assigned by means of parameters NCA1 to NCA8. They are configured using the graphic display terminal or integrated display terminal via the **[1.9 - COMMUNICATION] (C D P-)** menu and **[COM. SCANNER OUTPUT] (D C 5 -)** submenu. An NCA parameter with a value of zero does not designate any parameter in the drive. These 8 words are described in the table below:

Parameter name	Default assignment
[Scan.Out1 address] (n C A 1)	Command word (CMD)
[Scan.Out2 address] (n C A 2)	Speed target (LFRD)
[Scan.Out3 address] (n C A 3)	Not used
[Scan.Out4 address] (n C A 4)	Not used
[Scan.Out5 address] (n C A 5)	Not used
[Scan.Out6 address] (n C A 6)	Not used
[Scan.Out7 address] (n C A 7)	Not used
[Scan.Out8 address] (n C A 8)	Not used

The 8 periodic input variables are assigned by means of parameters NMA1 to NMA8. They are configured using the graphic display terminal or integrated display terminal via the [1.9 - COMMUNICATION] (CON-) menu and [COM. SCANNER INPUT] (ICS-) submenu. An NCA parameter with a value of zero does not designate any parameter in the drive. These 8 words are described in the table below:

Parameter name	Default assignment
[Scan. In1 address] (n P A 1)	Status word (ETA)
[Scan. In2 address] (n P A 2)	Output speed (RFRD)
[Scan. In3 address] (n P A 3)	Not used
[Scan. In4 address] (n P A 4)	Not used
[Scan. In5 address] (n P A 5)	Not used
[Scan. In6 address] (n P A 6)	Not used
[Scan. In7 address] (n P A 7)	Not used
[Scan. In8 address] (n P A 8)	Not used

Example of communication scanner configuration via the graphic display terminal:

RDY	MDB	+00.00Hz	0A
COM. SCANNER INPUT			<input type="checkbox"/>
Scan. In1 address	:		3201
Scan. In2 address	:		8604
Scan. In3 address	:		0
Scan. In4 address	:		0
Scan. In5 address	:		0
Code		Quick	<input checked="" type="checkbox"/>
Scan. In6 address	:		0
Scan. In7 address	:		0
Scan. In8 address	:		0

RDY	MDB	+00.00Hz	0A
COM. SCANNER OUTPUT			<input type="checkbox"/>
Scan.Out1 address	:		8501
Scan.Out2 address	:		8502
Scan.Out3 address	:		0
Scan.Out4 address	:		0
Scan.Out5 address	:		0
Code		Quick	<input checked="" type="checkbox"/>
Scan.Out6 address	:		0
Scan.Out7 address	:		0
Scan.Out8 address	:		0

Note : All modifications to parameters NMA1 ... NMA8 or NCA1 ... NCA8 must be made with the motor stopped. The master PLC program should be updated to take account of this modification.

Configuration

Configuring monitored parameters

Up to 4 parameters can be selected and their value displayed in the [\[1.2 - MONITORING\]](#) menu on the graphic display terminal.

The selection is made via the [\[6 – MONITOR CONFIG.\]](#) menu ([\[6.3 - CONFIG. COMM. MAP\]](#) submenu).

Each of the parameters [Address 1 select] ... [Address 4 select] can be used to select the logic address of the parameter. An address at zero is used to disable the function.

In the example given here, the monitored words are:

- Parameter 1 = Motor current (LCR): Logic address 3204; signed decimal format
- Parameter 2 = Motor torque (OTR): Logic address 3205; signed decimal format
- Parameter 3 = Last fault (LFT): Logic address 7121; hexadecimal format
- Disabled parameter: Address W0; default format: Hexadecimal format

RDY	MDB	+0.00Hz	0A
6.3 CONFIG. COMM. MAP			<input type="checkbox"/>
Address 1 select	:	3204	
Format address 1	:	Signed	
Address 2 select	:	3205	
Format address 2	:	Signed	
Address 3 select	:	7121	
Code		Quick	<input checked="" type="checkbox"/>
Format address 3	:	Hex	
Address 4 select	:	0	
Format address 3	:	Hex	

One of the three display formats below can be assigned to each monitored word:

Format	Range	Terminal display
Hexadecimal	0000 ... FFFF	[Hex]
Signed decimal	-32 767 ... 32 767	[Signed]
Unsigned decimal	0 ... 65 535	[Unsigned]

Note: If a monitored parameter:

- has been assigned to an unknown address (e.g., 3200)
- has been assigned to a protected parameter
- has not been assigned

the value displayed on the [\[COMMUNICATION MAP\]](#) screen will be "-----" (see "Diagnostics" section).

Configuration

Configuring communication fault management

If the drive does not receive any Modbus request sent to its address for a predefined period of time (time out), a Modbus fault is triggered. The "time out" can be set to between 0.1 and 30 s using the graphic display terminal or integrated display terminal via the **[Modbus time out] (t t D)** parameter in the **[1.9 COMMUNICATION] (C D n -)** menu (**[MODBUS NETWORK] (n d l -)** submenu). The default value is 10 s.

The response of the drive in the event of a Modbus communication fault can also be configured.

Configuration can be performed using the graphic display terminal or integrated display terminal via the **[Modbus fault mgt] (S L L)** parameter in the **[1.8 – FAULT MANAGEMENT] (F L t -)** menu (**[COM. FAULT MANAGEMENT] (C L L -)** submenu).

RDY	MDB	+0.00Hz	0A
COM. FAULT MANAGEMENT			<input type="checkbox"/>
Network fault mgt	:	Freewheel	
CANopen fault mgt	:	Freewheel	
Modbus fault mgt	:	Freewheel	
Code		Quick	<input type="checkbox"/>

The values of the **[Modbus fault mgt] (SLL)** parameter, which trigger a drive fault **[Modbus com.] (SLF1)**, are:

Value	Meaning
[Freewheel] (YES)	Freewheel stop (factory setting).
[Ramp stop] (rMP)	Stop on ramp.
[Fast stop] (FSt)	Fast stop.
[DC injection] (dCI)	DC injection stop.

The values of the **[Modbus fault mgt] (SLL)** parameter, which do not trigger a drive fault, are:

Value	Meaning
[Ignore] (nO)	Fault ignored.
[Per STT] (Stt)	Stop according to configuration of [Type of stop] (Stt) .
[fallback spd] (LFF)	Change to fallback speed, maintained as long as the fault persists and the run command has not been removed.
[Spd maint.] (rLS)	The drive maintains the speed at the time the fault occurred, as long as the fault persists and the run command has not been removed.

The fallback speed can be configured in the **[1.8 – FAULT MANAGEMENT] (FLt-)** menu using the **[Fallback speed] (LFF)** parameter.

Diagnostics

LEDs

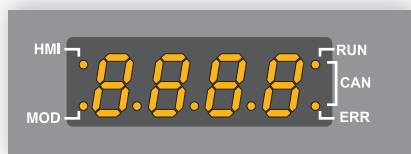

The **HMI** and **MOD** LEDs are located on the left-hand side of the 4-digit 7-segment display on the front of the Altivar 71. They indicate the status of Modbus communications.

HMI: Activity on Modbus HMI serial link

MOD: Activity on Modbus network serial link

Each LED lights up for 200 ms when a frame is being transmitted on the corresponding Modbus network, whether or not this is destined for the drive.

Note: Altivar 71 drives with high power ratings (>15 kW) do not feature an integrated display terminal. The **HMI** and **MOD** statuses are fed back to the graphic display terminal.

Diagnostics

Communication diagnostics

RUN	MDB	+50.00Hz	80A
COMMUNICATION MAP <input type="checkbox"/>			
Cmd Channel	:		Modbus
Cmd value	:		000F _{Hex}
Active ref. channel	:		Modbus
Frequency ref	:		500.0Hz
Status word	:		827 _{Hex}
Code		Quick	<input checked="" type="checkbox"/>
W3204	:		53
W3205	:		725
W7132	:		0000 _{Hex}
W0	:		-----
COM. SCANNER INPUT MAP			
COM SCANNER OUTPUT MAP			
CMD. WORD IMAGE			
FREQ. REF. WORD MAP			
MODBUS NETWORK DIAG			
MODBUS HMI DIAG			
CANopen MAP			
PROG. CARD SCANNER			

On the terminal, in the **[1.2 - MONITORING]** (*SUP -*) menu (**[COMMUNICATION MAP.]** (*С П П*) submenu):

- The **[MODBUS NETWORK DIAG]** submenu can be used to display the status of Modbus network communications.
- The **[MODBUS HMI DIAG]** submenu can be used to display the status of Modbus HMI communications.

RUN	MDB	+50.00Hz	80A
MODBUS NETWORK DIAG <input type="checkbox"/>			
COM LED	:		⊗
Mb1 process frames	:		568
Mb1 CRC errors	:		0
Code		Quick	<input type="checkbox"/>

RUN	MDB	+50.00Hz	80A
MODBUS HMI DIAG <input type="checkbox"/>			
Scan.Out1 address	:		⊗
Mb2 process frames	:		10753
Mb2 CRC errors	:		0
Code		Quick	<input type="checkbox"/>

LED display

- MOD LEDs: Modbus network activity
- HMI LED: Modbus HMI activity

The ⊗ symbol signifies a non-illuminated LED (no Modbus frames).

The ⊗ symbol signifies an illuminated LED (Modbus frame detected).

The LED remains illuminated for 200 ms whenever the drive detects transmission of a Modbus frame, even if the drive itself is not the intended recipient.

These LEDs are equivalent to the LEDs on the 7-segment integrated terminal (where supplied together with the drive).

The graphic display terminal is connected to Modbus HMI; the symbol assigned to the **[COM LED]** field in the **[MODBUS HMI DIAG]** submenu is always ⊗.

Diagnostics

Modbus counters

- **[Mb1 process frames]** and **[Mb2 process frames]** indicate the number of Modbus frames received. The counter counts both correct and incorrect frames.
- **[Mb1 CRC errors]** and **[Mb2 CRC errors]** indicate the number of Modbus frames containing checksum errors.

In the case of these two counters, only frames that are destined for the drive and whose Modbus address is supplied by the **[Modbus Address] (R d d)** parameter are counted. Broadcast frames are not counted.

[Mb1 process frames] and **[Mb2 process frames]** are modulo 65 536 counters, i.e., the value is reset to zero once the value of 65 535 is reached.

By contrast, the **[Mb1 CRC errors]** and **[Mb2 CRC errors]** remain at 65 535 once this value is reached.

Each Modbus counter corresponds to a drive parameter:

Menu	Parameter name	Code	Logical address
[MODBUS NETWORK DIAG]	[Mb1 process frames]	M1CT	6011
	[Mb1 CRC errors]	M1EC	6010
[MODBUS HMI DIAG]	[Mb2 process frames]	M2CT	6031
	[Mb2 CRC errors]	M2EC	6030

Diagnostics

Control-signal diagnostics

On the graphic display terminal, the **[1.2 - MONITORING]** (*S U P -*) menu (**[COMMUNICATION MAP]** (*С П П*) submenu) can be used to display control-signal diagnostic information between the Altivar 71 drive and the Modbus master:

- Active command channel
- Value of the command word (CMD) produced by the active command channel
- Active target channel
- Value of the target produced by the active target channel
- Value of the status word
- Values of four parameters selected by the user
- In the **[COM. SCANNER INPUT MAP]** submenu: Values of communication scanner input words
- In the **[COM SCANNER OUTPUT MAP]** submenu: Values of communication scanner output words
- In the **[CMD. WORD IMAGE]** submenu: Command words produced by all channels
- In the **[FREQ. REF. WORD MAP]** submenu: Frequency targets produced by all channels

Example of displaying communication diagnostic information

RUN	MDB	+50.00Hz	80A
COMMUNICATION MAP			<input type="checkbox"/>
Cmd Channel	:		Modbus
Cmd value	:		000F _{Hex}
Active ref. channel	:		Modbus
Frequency ref	:		500.0 _{Hex}
Status word	:		8627 _{Hex}
Code		Quick	<input checked="" type="checkbox"/>
W3204	:		53
W3205	:		725
W7132	:		0000 _{Hex}
W0	:		-----
COM. SCANNER INPUT MAP			
COM SCANNER OUTPUT MAP			
CMD. WORD IMAGE			
FREQ. REF. WORD MAP			
MODBUS NETWORK DIAG			
MODBUS HMI DIAG			
CANopen MAP			
PROG. CARD SCANNER			

Displaying the command word

The **[Cmd Channel]** parameter indicates the active command channel.

The **[Cmd value]** parameter indicates the hexadecimal value of the command word (CMD) used to control the drive.

The **[CMD. WORD IMAGE]** submenu (**[Modbus cmd.]** parameter) is used to display the hexadecimal value of the command word produced by Modbus.

Diagnostics

Displaying the frequency target

The **[Active ref. channel]** parameter indicates the active target channel.

The **[Frequency ref]** parameter indicates the value (in 0.1 Hz units) of the frequency target (LFR) used to control the drive.

The **[FREQ. REF. WORD MAP]** submenu (**[Modbus ref.]** parameter) is used to display the value (in 0.1 Hz units) of the speed target produced by Modbus.

Displaying the status word

The **[Status word]** parameter indicates the value of the status word (ETA).

Displaying parameters selected by the user

The four **[W●●●]** parameters indicate the value of the four words selected for monitoring by the user.

The address and display format of these parameters can be configured in the **[6 - MONITORING CONFIG.]** menu (**[6.3 - COM. MAP CONFIG.]** submenu).

The value of a monitored word equals "-----" if:

- Monitoring has not been activated (address equals W0)
- The parameter is protected
- The parameter is not known (e.g., W3200)

Displaying communication scanner values

On the graphic display terminal, in the **[1.2 - MONITORING]** (**5 U P -**) menu (**[COMMUNICATION MAP]** (**C P P -**) submenu):

- The **[COM. SCANNER INPUT MAP]** (**I S A -**) submenu is used to display the value of the 8 communication scanner input parameters NM1 to NM8.
- The **[COM SCANNER OUTPUT MAP]** (**O S A -**) submenu is used to display the value of the 8 communication scanner output parameters NC1 to NC8.

Configuration of these periodic parameters is described in the "Configuration" section.

Example of communication scanner display on the graphic display terminal:

RUN	MDB	+50.00Hz	80A
COM. SCANNER INPUT MAP <input type="checkbox"/>			
Com Scan In1 val.	:		34359
Com Scan In2 val.	:		600
Com Scan In3 val.	:		0
Com Scan In4 val.	:		0
Com Scan In5 val.	:		0
Code		Quick	<input checked="" type="checkbox"/>
Com Scan In6 val.	:		0
Com Scan In7 val.	:		0
Com Scan In8 val.	:		0

RUN	MDB	+50.00Hz	80A
COM SCANNER OUTPUT MAP <input type="checkbox"/>			
Com Scan Out1 val.	:		15
Com Scan Out2 val.	:		598
Com Scan Out3 val.	:		0
Com Scan Out4 val.	:		0
Com Scan Out5 val.	:		0
Code		Quick	<input checked="" type="checkbox"/>
Com Scan Out6 val.	:		0
Com Scan Out7 val.	:		0
Com Scan Out8 val.	:		0

In this example, only the first two parameters have been configured (default assignment).

[Com Scan In1 val.]	= [34343]	Status word = 34359 = 16#8637	→ Drivecom status "Operation enabled", reverse operation, speed reached.
[Com Scan In2 val.]	= [600]	Output speed = 600	→ 600 rpm
[Com Scan Out1 val.]	= [15]	Command word = 15 = 16#000F	→ "Enable operation" (Run) command
[Com Scan Out2 val.]	= [598]	Speed target = 600	→ 598 rpm

Communication faults

If there is no Modbus communication, the indicators of the integrated display terminal or graphic display terminal do not light. There is no specific indicator for Modbus communication fault.

In factory settings, a Modbus communication fault triggers a re-settable drive fault **[Modbus com.] (SLFI)** and a freewheel stop.

The response of the drive in the event of a CANopen communication fault can be changed (see "Configuring communication fault management") :

- Drive fault **[Modbus com.] (SLFI)** (freewheel stop, stop on ramp, fast stop or DC injection stop).
- No drive fault (stop, maintain, fallback).

The fault management is described in the user manual "Communication parameters", chapter "Communication monitoring" :

- After initialization (power up), the drive checks that at least one of the command or target parameters has been written once via Modbus.
- Then, if a Modbus communication fault occurs, the drive reacts according to the configuration (stop, maintain, fallback ...).

The Modbus communication fault is generated if the drive receives no request during a predefined period (see "Configuration of the communication fault management").

Every type of request is taken into account (write, read...).

If the drive is connected to a Modbus communication gateway, the upper level network may be connected to :

- a PLC that commands the drive,
- an industrial display terminal (Magelis) or a SCADA that monitors the drive.

If the PLC fails, the SCADA may go on transmitting Modbus requests to the drive. In this case, the Modbus communication fault will not appear.

Modbus protocol

RTU mode

The transmission mode used is RTU mode. The frame contains no message header byte, nor end of message bytes. It is defined as follows:

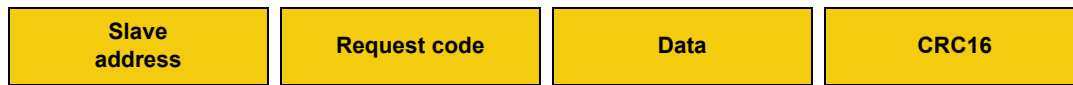

The data is transmitted in binary code.

CRC16: cyclic redundancy check parameter.

The end of the frame is detected on a silence greater than or equal to 3.5 characters.

Principle

The Modbus protocol is a master-slave protocol.

Only one device can transmit on the line at any time.

The master manages the exchanges and only it can take the initiative.

It interrogates each of the slaves in succession.

No slave can send a message unless it is invited to do so.

In the event of an error during data exchange, the master repeats the question and declares the interrogated slave absent if no response is received within a given time period.

If a slave does not understand a message, it sends an exception response to the master. The master may or may not repeat the request.

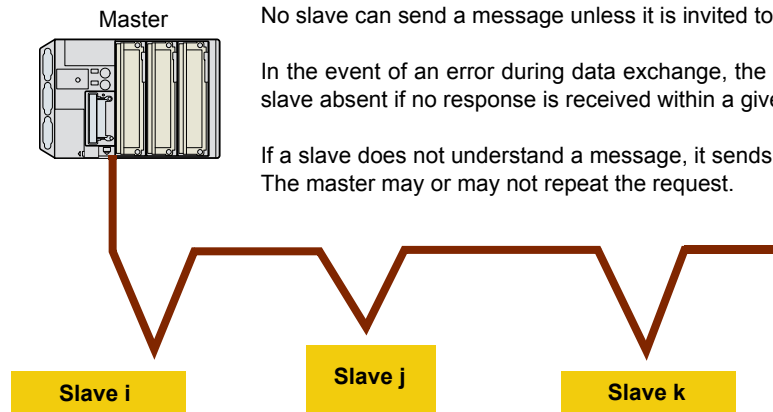

Direct slave-to-slave communications are not possible.

For slave-to-slave communication, the application software must therefore be designed to interrogate one slave and send back data received to the other slave.

Two types of dialog are possible between master and slaves:

- The master sends a request to a slave and waits for it to respond
- The master sends a request to all slaves without waiting for them to respond (broadcasting principle)

Modbus protocol

Altivar 71 Integrated Modbus

The Altivar 71 features 2 integrated Modbus ports:

- Modbus network
- Modbus HMI

These 2 ports are physically independent of one another. They are connected to 2 different Modbus networks, each with its own master. Different speeds and formats are possible in each case.

These 2 networks provide access to the drive's 3 Modbus servers, which are identified by their address. The address of each server is the same on both networks.

These 2 networks constitute a single channel: The drive makes no distinction between the commands and targets that come from the 2 ports (i.e., the 2 Modbus masters).

In practice, a single PLC or industrial HMI terminal (Magelis type) controls the drive.

The display terminal and PowerSuite are also Modbus masters, but benefit from designated channels. They are identified as setup tools and make use of specific services.

Addresses

- The Modbus addresses of the drive can be configured from 1 to 247.
- Address 0 coded in a request sent by the master is reserved for broadcasting. ATV 71 drives take account of the request, but do not respond to it.

The drive has 3 Modbus servers, each with its own address:

- One Modbus server for the drive parameters
- One Modbus server for the variables (%MW...) of the "Controller inside" programmable card
- One Modbus server for the communication card (Ethernet) parameters

The addresses of these servers are identical for both Modbus network and Modbus HMI. The assignment of these addresses is subject only to the following regulations:

- Addresses must be between 1 and 247.
- Each address must be unique within the context of the network.

Modbus protocol

Modbus functions

The following table indicates which Modbus functions are managed by the Altivar 71, and specifies their limits. The "read" and "write" functions are defined from the point of view of the master.

Code	Modbus name	Function name	Broadcast	Max. value of N
3 = 16#03	Read Holding Registers	Read N output words	NO	63 words max.
6 = 16#06	Write Single Register	Write one output word	YES	–
8 = 16#08	Diagnostics	Diagnostics	NO	
16 = 16#10	Write Multiple Registers	Write N output words	YES	61 words max.
23 = 16#17	Read/Write Multiple Registers	Read/write N words	NO	20/20 words max.
43 = 16#2B	Read Device Identification	Identification	NO	–

Read N output words: Function 3

Note: Hi = high order byte, Lo = low order byte.

This function can be used to read the ATV 71 parameters, regardless of type.

Request

Slave no.	03	No. of first word Hi Lo	Number of words Hi Lo	CRC16 Lo Hi
1 byte	1 byte	2 bytes	2 bytes	2 bytes

Response

Slave no.	03	Number of bytes read	First word value Hi Lo	-----	Last word value Hi Lo	CRC16 Lo Hi
1 byte	1 byte	1 byte	2 bytes		2 bytes	2 bytes

Example 1: Use function 3 to read 4 words W3 102 to W3 105 (16#0C1E to 16#0C21) on slave 2, where:

- SFr = Switching frequency = 4 kHz (W3 102 = 16#0028)
- tFr = Maximum output frequency = 60 Hz (W3 103 = 16#0258)
- HSP = High speed = 50 Hz (W3 104 = 16#01F4)
- LSP = Low speed = 0 Hz (W3 105 = 16#0000)

Request

02	03	0C1E	0004	276C
----	----	------	------	------

Response

02	03	08	0028	0258	01F4	0000	52B0
Value of:		W3 102	W3 103	W3 104	W3 105		
Parameters:		SFr	tFr	HSP	LSP		

Modbus protocol

Example 2: Use function 3 to read 5 memory words %MW20 (16#0014) to %MW24 (16#0018) on the “Controller Inside” card (catalog number: VW3 A3 510); the Modbus server address for this card is configured using the **[Modbus add CI card] (RNDR)** parameter: Modbus address 54 (16#36). The five values read are as follows: 16#0054, 16#0123, 16#01A3, 16#1AD5, and 16#009E.

Request

36	03	0014	0005	C18A
----	----	------	------	------

Response

36	03	0A	0054	0123	01A3	1AD5	009E	214C
			%MW20	%MW21	%MW22	%MW23	%MW24	

Example 3: Use function 3 to read the current value of the Ethernet card IP address (reference: VW3 A3 310); the Modbus server address for this card is configured using the **[Mdb add com card] (RNDL)** parameter: Modbus address 104 (16#68). The 4 consecutive addresses used for this IP address run from 60 006 (16#EA66) to 60 009 (16#EA69) and their values are equal to 16#008B, 16#00A0, 16#0045, and 16#F1 (IP address = IPC1.IPC2.PC3.IPC4 = 139.160.69.241).

Request

68	03	EA66	0004	9937
----	----	------	------	------

Response

68	03	08	008B	00A0	0045	00F1	2E0A
			IPC1	IPC2	IPC3	IPC4	

Write one output word: Function 6

Request and response (the frame format is identical)

Slave no.	06	Word number		Value of word		CRC16	
		Hi	Lo	Hi	Lo	Lo	Hi
1 byte	1 byte	2 bytes		2 bytes		2 bytes	

Example: Write value 16#000D to word W9 001 (16#2329) on slave 2 (ACC = 13 s).

Request and response

02	06	2329	000D	9270
----	----	------	------	------

Modbus protocol

Diagnostics: Function 8

Subcode 16#00: Echo

This function asks the slave being interrogated to echo (return) the message sent by the master in its entirety.

Subcode 16#0A: Counter reset

This function resets all the counters responsible for monitoring a slave's exchanges.

Subcode 16#0C: Read message counter responsible for counting messages received with checksum errors

Subcode 16#0E: Read message counter responsible for counting messages addressed to slave

Read a word indicating the total number of messages addressed to the slave, regardless of type (excluding broadcast messages).

Request and response

Slave no.	08	Subcode		Data		CRC16	
		Hi	Lo	Hi	Lo	Lo	Hi
1 byte	1 byte	2 bytes		N bytes		2 bytes	

Subcode	Request data	Response data	Function executed
00	XX YY	XX YY	Echo
0A	00 00	00 00	Counter reset
0C	00 00	XX YY (= counter value)	Read message counter responsible for counting messages received with checksum errors
0E	00 00	XX YY (= counter value)	Read message counter responsible for counting messages addressed to slave

Example: Values 16#31 and 16#32 echoed by slave 4

Request and response (if function successful)

Slave no.	Request code or Response code	Subcode		Value of 1 st byte	Value of 2 nd byte	CRC16	
		Hi	Lo			Lo	Hi
04	08	00	00	31	32	74	1B

(hexadecimal values)

Modbus protocol

Write N output words: Function 16 (16#10)

Request

Slave no.	10	No. of first word		Number of words		Number of bytes	Value of first word		----- CRC16	
		Hi	Lo	Hi	Lo		Hi	Lo	Lo	Hi
1 byte	1 byte	2 bytes		2 bytes		1 byte	2 bytes		2 bytes	

Response

Slave no.	10	No. of first word		Number of words		CRC16	
		Hi	Lo	Hi	Lo	Lo	Hi
1 byte	1 byte	2 bytes		2 bytes		2 bytes	

Example: Write values 20 and 30 to words W9 001 and W9 002 on slave 2 (acceleration time = 20 s and deceleration time = 30 s)

Request

Slave no.	Request code	No. of first word		Number of words		Number of bytes	Value of first word		Value of second word		CRC16	
		Hi	Lo	Hi	Lo		Hi	Lo	Hi	Lo	Lo	Hi
02	10	23	29	00	02	04	00	14	00	1E	73	A4

Response

Slave no.	Response code	No. of first word		Number of words		CRC16	
		Hi	Lo	Hi	Lo	Lo	Hi
02	10	23	29	00	02	9B	B7

(hexadecimal values)

Modbus protocol

Identification: Function 43 (16#2B)

Request

Slave no.	2B	Type of MEI 0E	ReadDeviceId 01	Object Id 00	CRC16	
1 byte	1 byte	1 byte	1 byte	1 byte	Lo	Hi
					2 bytes	

Response

Slave no.	2B	Type of MEI 0E	ReadDeviceId 01	Degree of conformity 02	-----
1 byte	1 byte	1 byte	1 byte	1 byte	
-----		Number of additional frames 00		Next object Id 00	Number of objects 04
		1 byte	1 byte	1 byte	-----
-----		Id of object no. 1 00	Length of object no. 1 0D	Value of object no. 1 "Schneider-Electric"	
		1 byte	1 byte	18 bytes	
-----		Id of object no. 2 01	Length of object no. 2 0B	Value of object no. 2 "ATV71HU15M3"	
		1 byte	1 byte	11 bytes	
-----		Id of object no. 3 02	Length of object no. 3 04	Value of object no. 3 "0201"	
		1 byte	1 byte	4 bytes	
-----		Id of object no. 4 06	Length of object no. 4 09	Value of object no. 4 "MACHINE 4"	
		1 byte	1 byte	9 bytes	
-----		CRC16			
		Lo	Hi		
		1 byte	1 byte		

The total response size given in this example equals 55 bytes

The response contains the following four objects:

- Object no. 1: Manufacturer name (always "Schneider-Electric", i.e., 18 bytes).
- Object no. 2: Device reference (ASCII string; for example: "ATV71HU15M3", i.e., 11 bytes).
The length of this object varies according to drive type. Use the "Length of object no. 2" field to determine the length.
- Object no. 3: Device version, in "MMmm" format where "MM" represents the determinant and "mm" the subdeterminant (4-byte ASCII string; *for example*: "0201" for version 2.1).
- Object no. 4: Device name (ASCII string; for example: "MACHINE 4", i.e., 9 bytes).
The length of this object varies according to the device name assigned to the drive (the latter being configured by the user): [\[7. DISPLAY CONFIG.\]](#) menu, [\[7.1 USER PARAMETERS\]](#) submenu, [\[DEVICE NAME\]](#) parameter.
Maximal length 16 bytes.

Modbus protocol

Negative response specifically related to identification function

Slave no.	2B + 80 AB	Type of MEI 0E	Error code 00 to 02	CRC16	
				Lo	Hi
1 byte	1 byte	1 byte	1 byte	1 byte	1 byte

Error code:

- 16#00 = No error
- 16#01 = The "Request code" (16#2B), the "Type of MEI" (16#0E) or the "ReadDeviceId" (16#01) contained in the request is incorrect
- 16#02 = The "Object Id" (16#00) contained in the request is incorrect

Example of positive response: Following the request from the Modbus master, slave 2 identifies itself as follows:

- Manufacturer name = "Schneider-Electric"
- Device name = "ATV71HU15M3"
- Device version = "0201"
- Device name = "MACHINE 4"

Request

Slave no.	Request code	Type of MEI	ReadDeviceId	Object Id	CRC Lo	CRC Hi
02	2B	0E	01	00	34	77

Response

Slave no.	Response code	Type of MEI	ReadDeviceId	Degree of conformity	No. of additional frames	Next object Id	Object no.
02	2B	0E	01	02	00	00	04

Id of object no. 1	Length of object no. 1	Value of object no. 1												
		'T'	'e'	'l'	'e'	'm'	'e'	'c'	'a'	'n'	'i'	'q'	'u'	'e'
00	0D	54	65	6C	65	6D	65	63	61	6E	69	71	75	65

Id of object no. 2	Length of object no. 2	Value of object no. 2										
		'A'	'T'	'V'	'7'	'1'	'H'	'U'	'1'	'5'	'M'	'3'
01	0B	41	54	56	37	31	48	55	31	35	4D	33

Id of object no.	Length of object no. 3	Value of object no. 3			
		'0'	'2'	'0'	'1'
02	04	30	32	30	31

Id of object no. 4	Length of object no. 4	Value of object no. 4									CRC Lo	CRC Hi
		'M'	'A'	'C'	'H'	'I'	'N'	'E'	' '	'4'		
06	09	4D	41	43	48	49	4E	45	20	34	6F	50

Modbus protocol

Read/write N words: Function 23 (16#17)

Request

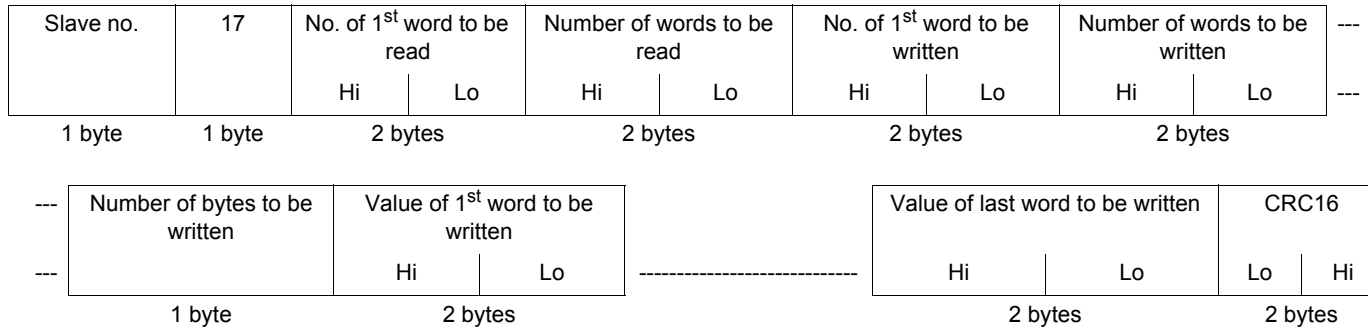

Response

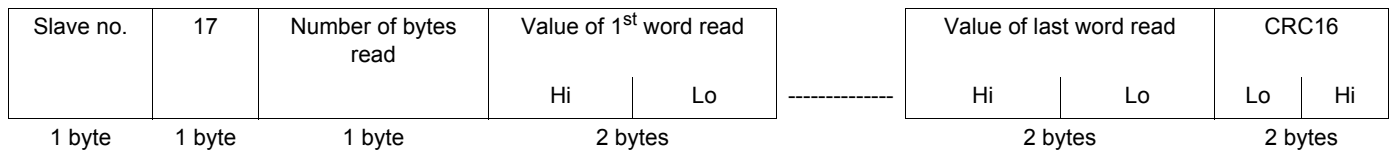

Example: This example combines the two examples for functions 3 and 16. With function 23, the line is less busy than with these two functions. However, the number of words that can be read and written is restricted.

- Write values of 20 (16#14) and 30 (16#1E) respectively to the 2 words W9 001 and W9 002 on slave 2.
- Read the 4 words W3 102 to W3 105 on the same slave (values read = 16#0028, 16#0258, 16#01F4, and 16#0000).

Request

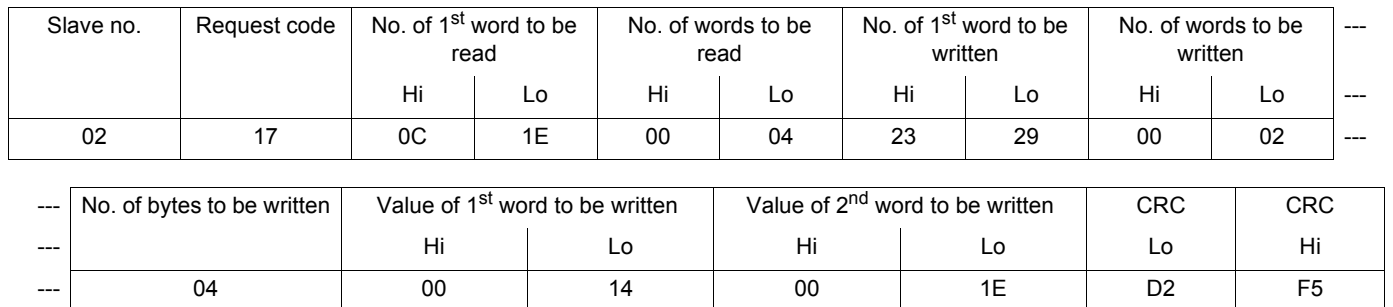

Response

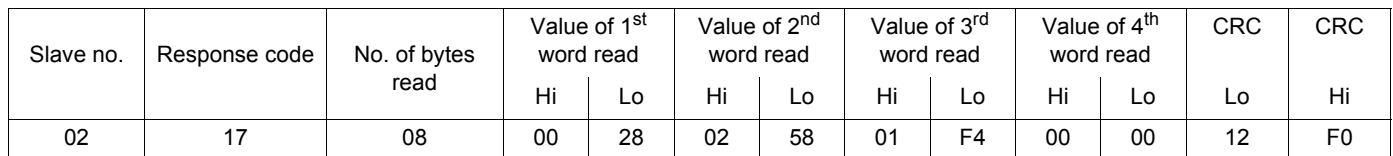

Modbus protocol

Communication scanner

To improve communication performance with an Altivar 71, non-contiguous drive parameters can be copied automatically to contiguous parameters. Thus, the copy of several non-contiguous drive parameters can be read or written using a single read and/or write request (an operation, which would normally have required several Modbus requests).

This function is called the "communication scanner".

The Altivar 71 communication scanner supports up to eight control scanner parameters and eight monitoring scanner parameters.

These parameters can be accessed via all the read and write requests supported by the Altivar 71.

There is a marked improvement in performance for the following functions:

Code	Modbus name	Function name	Max. value of N
3 = 16#03	Read Holding Registers	Read N output words	63 words max.
16 = 16#10	Write Multiple Registers	Write N output words	61 words max.
43 = 16#2B	Read Device Identification	Identification	–

The eight control scanner parameters are NC1 to NC8 (W12 761 to W12 708).
Their addresses are NCA1 to NCA8 (W12 721 to W12 728).

The eight monitoring scanner parameters are NM1 to NM8 (W12 741 to W12 748).
Their addresses are NMA1 to NMA8 (W12 701 to W12 708).

Configuration of the communication scanner is described in the "Configuration" section.

Example of how scanner parameters can be used:

- Use of the "Read/write N words" function (request code = 23 = 16#17)
- Transmission of the request to an Altivar 71 located at address 20 (16#14)
- Read all 8 monitoring scanner parameters (NM1 to NM8: W12 741 to W12 748 = addresses 16#31C5 to 16#31CC)
- List of source parameters:

No.	Parameter	Logical address	Read value
1	ETA	W3 201	16#0007
2	RFRD	W8 604	16#1388
3	LCR	W3 204	16#0064
4	OTR	W3 205	16#0045

No.	Parameter	Logical address	Read value
5	ULN	W3 207	16#00F0
6	THD	W3 209	16#0065
7	THR	W9 630	16#0032
8	LFT	W7 121	16#0000

- Write first 6 control scanner parameters (NC1 to NC6: W12 761 to W12 766 = addresses 16#31D9 to 16#31DE)
- List of target parameters:

No.	Parameter	Logical address	Value to be written
1	CMD	W8 501	16#000F
2	LFRD	W8 602	16#1388
3	HSP	W3 104	16#1F40
4	LSP	W3 105	16#01F4

No.	Parameter	Logical address	Value to be written
5	ACC	W9 001	16#04B0
6	DEC	W9 002	16#0258
7	-	W0	16#0000
8	-	W0	16#0000

Modbus protocol

The control scanner and monitoring scanner parameters are configured via the display terminal as follows:

Command

Menu	Value	Code	Parameter name
[Scan.Out1 address] (nCR1)	8 501	CMD	Command word
[Scan.Out2 address] (nCR2)	8 602	LFRD	Speed target
[Scan.Out3 address] (nCR3)	3 104	HSP	High speed
[Scan.Out4 address] (nCR4)	3 105	LSP	Low speed
[Scan.Out5 address] (nCR5)	9 001	ACC	Acceleration time
[Scan.Out6 address] (nCR6)	9 002	DEC	Deceleration time
[Scan.Out7 address] (nCR7)	0		
[Scan.Out8 address] (nCR8)	0		

Monitoring

Menu	Value	Code	Parameter name
[Scan. In1 address] (nPI1)	3 201	ETA	Status word
[Scan. In2 address] (nPI2)	8 604	RFRD	Output speed
[Scan. In3 address] (nPI3)	3 204	LCR	Motor current
[Scan. In4 address] (nPI4)	3 205	OTR	Torque
[Scan. In5 address] (nPI5)	3 207	ULN	Mains voltage
[Scan. In6 address] (nPI6)	3 209	THD	Thermal state of the drive
[Scan. In7 address] (nPI7)	9 630	THR	Thermal state of the motor
[Scan. In8 address] (nPI8)	7 121	LFT	Last fault

Request

Slave no.	Request code	No. of 1 st word to be read		No. of words to be read		No. of 1 st word to be written		No. of words to be written		No. of bytes to be written
		Hi	Lo	Hi	Lo	Hi	Lo	Hi	Lo	
14	17	31	C5	00	08	31	D9	00	06	0C

Value of 1 st word to be written		Value of 2 nd word to be written		Value of 3 rd word to be written		Value of 4 th word to be written		Value of 5 th word to be written		Value of 6 th word to be written		CRC	CRC
Hi	Lo	Hi	Lo	Hi	Lo	Hi	Lo	Hi	Lo	Hi	Lo		
00	0F	13	88	1F	40	01	F4	04	B0	02	58	56	3D

Response

Slave no.	Response code	No. of bytes read	Value of 1 st word read		Value of 2 nd word read		Value of 3 rd word read		Value of 4 th word read	
			Hi	Lo	Hi	Lo	Hi	Lo	Hi	Lo
14	17	10	00	07	13	88	00	64	00	45

Value of 5 th word read		Value of 6 th word read		Value of 7 th word read		Value of 8 th word read		CRC	CRC
Hi	Lo	Hi	Lo	Hi	Lo	Hi	Lo		
00	F0	00	65	00	32	00	00	E4	90

Modbus protocol

Exception responses

An exception response is returned by a slave when it is unable to perform the request, which is addressed to it.

Format of an exception response:

Slave no.	Response code	Error code	CRC16	
			Lo	Hi
1 byte	1 byte	1 byte	2 bytes	

Response code: Function code of the request + 16#80 (the most significant bit is set to 1).

Error code:

- 1 = The function requested is not recognized by the slave.
- 2 = The word addresses indicated in the request do not exist in the slave.
- 3 = The word values indicated in the request are not permissible in the slave.
- 4 = The slave has started to execute the request but cannot continue to process it completely.

Example: Write the value 1 to word ETA = W3 201 (which cannot be written, as in "read-only" mode) on slave 4.

Request

Slave no.	Request code	No. of 1st word		No. of words		No. of bytes	Value of 1st word		CRC Lo	CRC Hi
		Hi	Lo	Hi	Lo		Hi	Lo		
04	10	0C	81	00	01	02	00	01	8A	D1

Response

Slave no.	Response code	Error code	CRC Lo	CRC Hi
04	10 + 80 = 90	04	5D	C2

Read non-existent or protected parameters

If a set of parameters is read using a Modbus function, the value returned for non-existent and protected parameters is equal to 16#8000.

If the same Modbus function is used to read parameters, all of which are non-existent or protected, the drive sends back an exception response with an error code equal to 2.

Example of non-existent or protected parameters being read:

In this example, the same read request is used several times in a row for a non-existent parameter (W8400), CHCF (W8401) and COP (W8402) in order to demonstrate the effects of parameter protection.

The read request is a Read N output words request (function 3) and is addressed to a drive whose Modbus address is equal to 12 (16#0C). The read operation is performed for 3 consecutive words, starting with address W8400 (16#20D0).

The value of CHCF is equal to 16#0003 (I/O profile) and the value of COP is equal to 16#0002 (copy of the command word on switching from command channel no. 1 to command channel no. 2).

Read N output words request:

Slave no.	Request code	No. of 1st word		No. of words		CRC16	
		Hi	Lo	Hi	Lo	Lo	Hi
0C	03	20	D0	00	03	0E	EF

Modbus protocol

Response to the Read N output words request:

Scenario no. 1: Parameters CHCF (W8 401) and COP (W8 402) not protected → Successful reading of these two parameters and value equal to 16#8000 for the non-existent parameter located at address W8 400.

Slave no.	Response code	No. of bytes read	Value of W8 400		Value of W8 401		Value of W8 402		CRC16	
			Hi	Lo	Hi	Lo	Hi	Lo	Lo	Hi
0C	03	06	80	00	00	03	00	02	17	E4

Scenario no. 2: Parameter CHCF (W8 401) protected and COP (W8 402) not protected → Successful reading of COP and value equal to 16#8000 for the non-existent parameter located at address W8 400 and for parameter CHCF.

Slave no.	Response code	No. of bytes read	Value of W8 400		Value of W8 401		Value of W8 402		CRC16	
			Hi	Lo	Hi	Lo	Hi	Lo	Lo	Hi
0C	03	06	80	00	80	00	00	02	CE	24

Scenario no. 3: Parameters CHCF (W8 401) and COP (W8 402) protected → Exception response (response code = 16#80 + request code), as all the parameters read are either non-existent, or protected; error code equal to 2 (the word addresses indicated in the request do not exist in the slave).

Slave no.	Response code	Error code	CRC16	
			Lo	Hi
0C	80+03 = 83	02	51	32

Appendix: Non-standard schematics

UNI-TELWAY schematic

Schneider-Electric used the UNI-TELWAY bus schematic for drives and soft starters (ATV58, ATV28, ATS48, etc.) sold prior to the publication of the Modbus specifications on www.modbus.org. In the case of the ATV31 and ATV71 speed drives, the standard schematic applies (see page 9).

Schematic diagram:

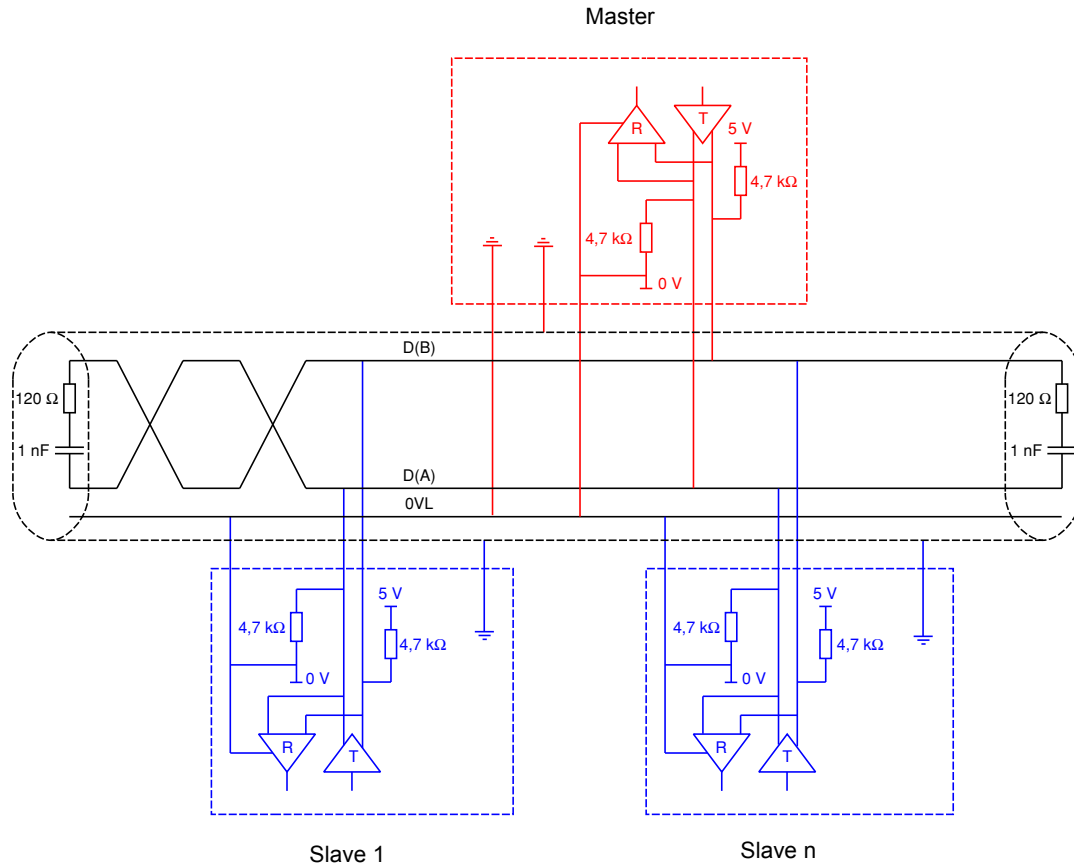

Type of trunk cable	Cable with 2 twisted pairs shielded in pairs
Maximum length of bus	1000 m at 19200 bps
Maximum number of stations (without repeater)	29 stations, i.e., 28 slaves
Maximum length of tap links	<ul style="list-style-type: none"> • 20 m • 40 m divided by the number of tap links on a multiple junction box
Bus polarization	For the master and each slave: <ul style="list-style-type: none"> • One 4.7 kΩ pull-down resistor at 5 V • One 4.7 kΩ pull-down resistor at 0 VL
Line terminator	One 120 Ω 0.25 W resistor in series with a 1 nF 10 V capacitor
Common polarity	Yes (0 VL) and high impedance placed between 0 VL and the ground in each station

Appendix: Non-standard schematics

Jbus schematic

Schematic diagram:

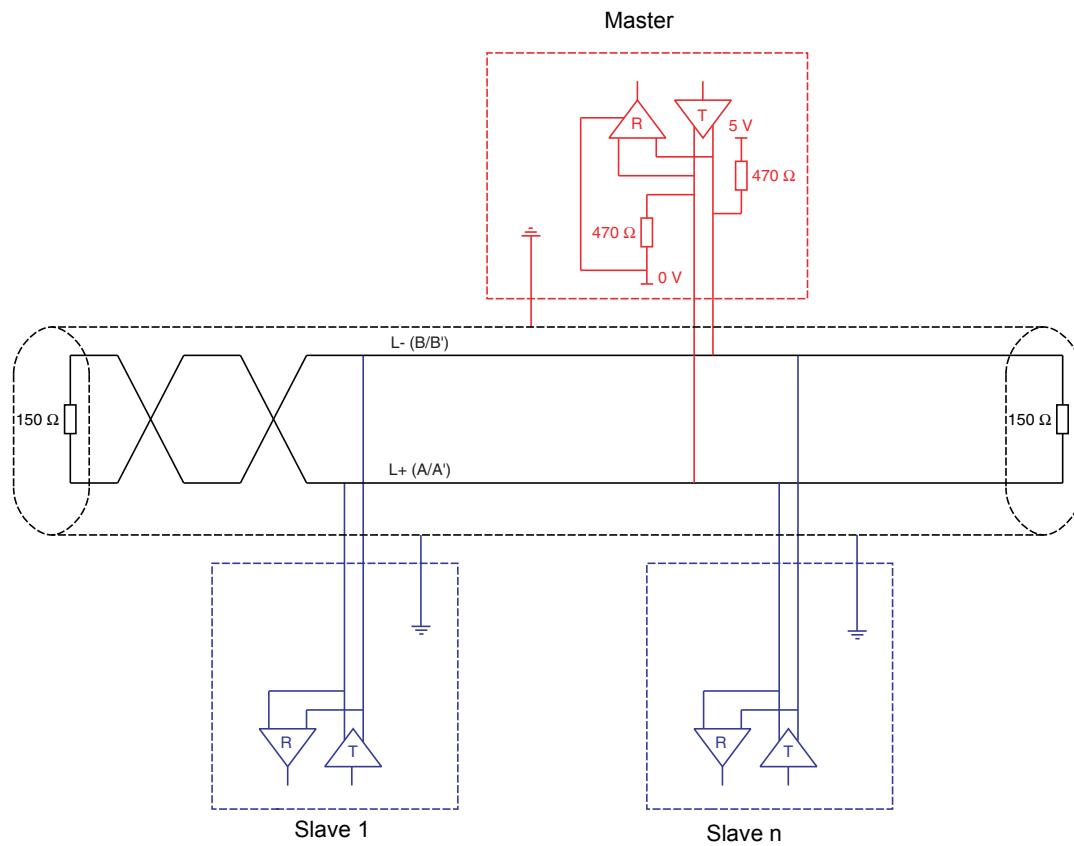

Type of trunk cable	Cable with 1 shielded twisted pair
Maximum length of bus	1300 m at 19200 bps
Maximum number of stations (without repeater)	32 stations, i.e., 31 slaves
Maximum length of tap links	3 m
Bus polarization	One 470 Ω pulldown resistor at 5 V One 470 Ω pulldown resistor at 0 V This polarization is often provided in the master.
Line terminator	One 150 Ω resistor
Common polarity	No

Appendix: Non-standard schematics

Use of UNI-TELWAY slaves in a standard schematic

Slaves with 4.7kΩ polarization can be integrated into a standard schematic. Suitable polarization resistance (Rp) must be calculated.

Schematic diagram:

In this example, slave 1 has a 4.7 kΩ polarization.

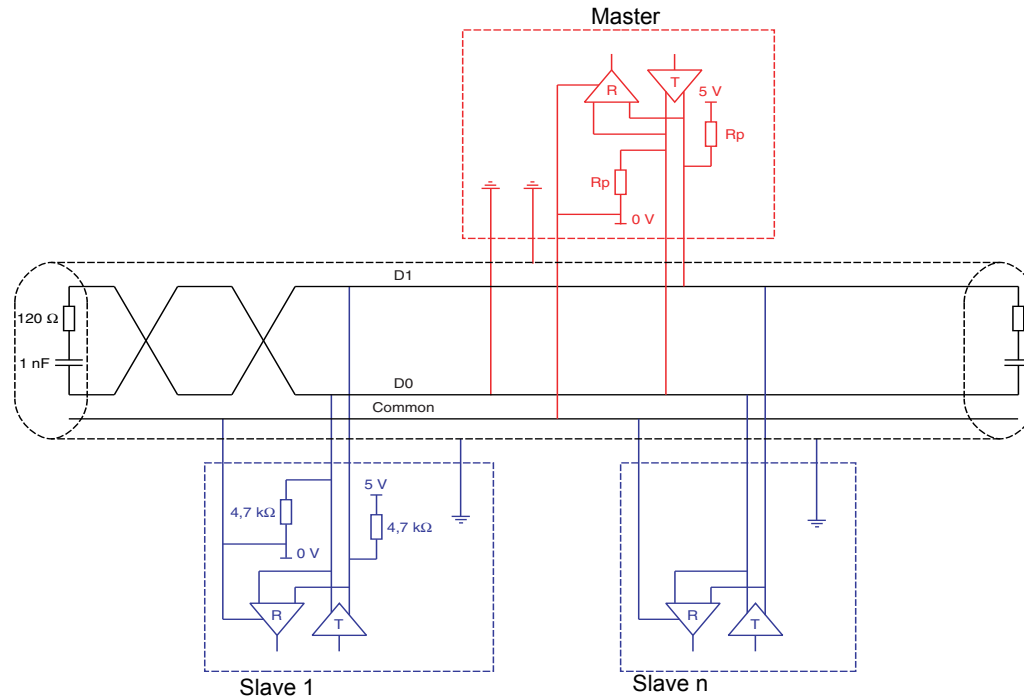

Type of trunk cable	Shielded cable with 1 twisted pair and at least a 3 rd conductor
Maximum length of bus	1000 m at 19200 bps
Maximum number of stations (without repeater)	Up to 32 stations, i.e., 31 slaves (depending on Rp and the number of 4.7 kΩ resistors)
Maximum length of tap links	<ul style="list-style-type: none"> • 20 m for a single tap link • 40 m divided by the number of tap links on a multiple junction box
Bus polarization	<ul style="list-style-type: none"> • One pull-down resistor at 5 V (Rp) • One pull-down resistor at the Common (Rp) This polarization can be provided in the master. The value of Rp should be validated (or determined) by calculating the equivalent polarization (Re) according to the polarization of the master and slave stations. The value of Re must be between 162 Ω and 650 Ω (recommended value: 650 Ω).
Line terminator	One 120 Ω 0.25 W resistor in series with a 1 nF 10 V capacitor
Common polarity	Yes (Common)

- If the master has a 470 Ω polarization and all the slaves have 4.7 kΩ polarization, up to 18 slaves can be connected.
- To calculate the polarization resistance (Rp), all station polarizations must be deemed to be connected in parallel.

Example:

If the bus Rp polarization is 470 Ω (installed in the master) and 2 slaves have 4700 Ω polarization, the equivalent polarization is:

$$1/Re = 1/470 + 1/4700 + 1/4700,$$

$$\text{i.e., } Re = 1 / (1/470 + 1/4700 + 1/4700)$$

and therefore Re = 390 Ω.

390 Ω is greater than 162 Ω, and the schematic is correct.

For an ideal equivalent polarization (650 Ω), Rp bus polarization can be installed so that:

$$1/650 = 1/Rp + 1/4700 + 1/4700,$$

$$\text{i.e., } Rp = 1 / (1/650 - 1/4700 - 1/4700)$$

and therefore Rp = 587 Ω.

Appendix: Non-standard schematics

Recommendations for setting up a Modbus network using non-standard devices

1. Identify polarities D0 and D1.

They are labeled in a variety of ways according to the specification used:

Modbus	D0	D1	Common
EIA/TIA-485	A / A'	B / B'	C / C'
UNI-TELWAY	D(A)	D(B)	0VL
Jbus	RD + / TD + L +	RD - / TD - L -	

However, certain RS485 electronic components are labeled in the opposite way to the EIA/TIA-485 standard.

It may be necessary to perform a test by connecting a master to a slave, then reversing the connection in the event of failure.

2. Check polarizations.

Study the documentation supplied with the devices to determine the polarization resistance.

If there is one, check that the value is correct (see Use of UNI-TELWAY slaves in a standard schematic page [43](#))

Polarization is not always possible. For example, in the event of the 5 V not being available in the master.

3. Select a line terminator.

In the case of polarization, select an RC line terminator ($R = 120 \Omega$, $C = 1 \text{ nF}$).

If polarization is not possible, select an R line terminator ($R = 150 \Omega$).

